

YAMAHA

LSI

YM2413

DEC 3 1986

NO.86-04

JAN 15 1988

N3C

YM2413

FM OPERATOR TYPE-LL(OPLL)

MP 08 2700

■ OUTLINE

This LL-Type FM Operator incorporates a DA Converter and a Quartz Oscillator in addition to a YAMAHA original FM Sound Generator, allowing for a much easier and economical sound generating system assembly than conventional LSIs. Tone data are stored in ROM for software simplicity, making it possible to execute data alterations involved in tone changes with just one Instruments selection operation. Furthermore, a built-in Tone Data Register with capacity for one tone permits sound effects and original tones generation. Tones applicable to the "CAPTAIN" and TELETEXT are included among built-in tone data.

■ FEATURES

- FM Sound Generator for real sound creation.
- Two selectable modes: 9 simultaneous sounds or 6 melody sounds plus 5 rhythm sounds (different tones can be used together in either case).
- Built-in Instruments data (15 melody tones, 5 rhythm tones, "CAPTAIN" and TELETEXT applicable tones).
- Built-in DA Converter.
- Built-in Quartz Oscillator.
- Built-in Vibrato Oscillator/AM Oscillator.
- TTL Compatible Input.
- Si-Gate NMOS LSI.
- A single 5V power source.

8001-5025

EDITOR

NIPPON GAKKI CO., LTD.

CATALOG No.: LSI-2124130

YAMAHA

YM2413

■ PIN ASSIGNMENT

GND	1	18	DI
D2	2	17	DO
D3	3	16	VCC
D4	4	15	RO
D5	5	14	MO
D6	6	13	IC
D7	7	12	CS
XIN	8	11	WE
XOUT	9	10	AO

■ BLOCK DIAGRAM

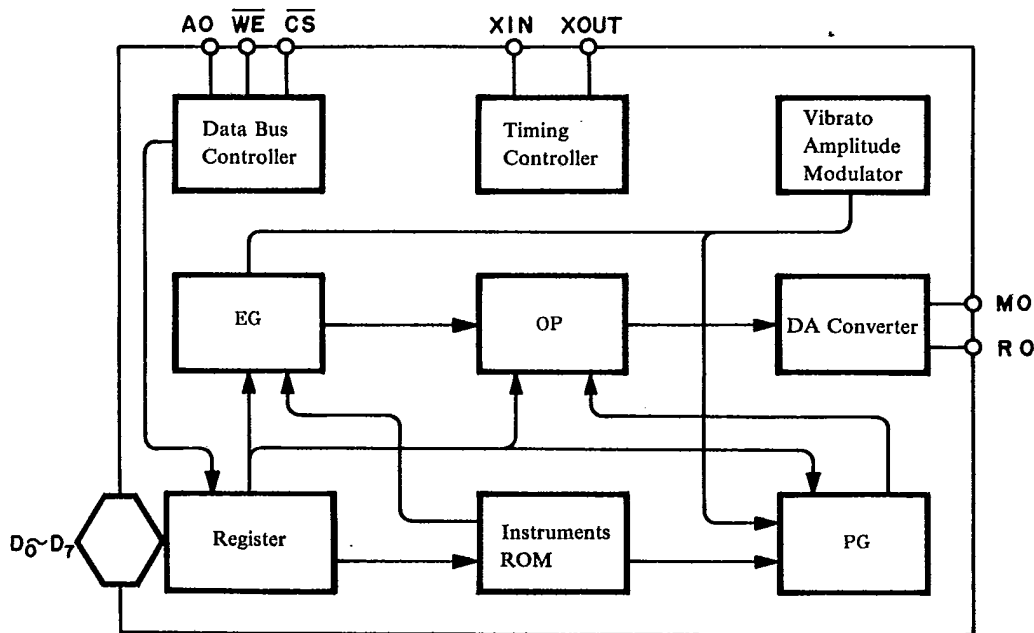

■ PIN FUNCTIONS

SYMBOL	I/O	FUNCTION		
XIN XOUT	I O	A quartz oscillator (3.579545 MHz) is connected between these two pins.		
D ₀ ? D ₇	I/O	8-Bit Data Bus for OPLL control.		
A ₀	I	For controlling the D ₀ ~D ₇ Data Bus.		
\overline{CS}		\overline{CS} \overline{WE} A ₀	0 0 0	Writes register address into OPLL.
\overline{WE}		0 0 1	Writes register contents into OPLL.	
		0 1 0	Outputs OPLL test data to D ₀ /D ₁ Pins. Normally not used.	
		0 1 1	OPLL Data Bus high impedance	
0 x x				
\overline{IC}	I	Resets the system when level is low, clearing OPLL Registers.		
MO RO	O	Melody (MO) and Rhythm (RO) Outputs. Both sound types are output by a source follower. Integrated circuitry and an amplifier are necessary for subsequent processing.		
Vcc	I	+5V Power Pin.		
GND	—	Ground Pin.		

■ EXPLANATION OF FUNCTIONS

This OPLL is a FM Sound Generator LSI with a built-in 9-Bit DA Converter. It has two sound generation modes: 9 melody sounds or 6 melody sounds plus 5 rhythm sounds, both allowing for simultaneous generation of different tones. Selection between these two modes can be performed from the software. One of the special features of this LSI is its built-in Instruments ROM. As shown in the table hereunder, this ROM incorporates 15 melody tones and 5 rhythm tones, as well as all tones used for "CAPTAIN" and TELETXT for easy application to "CAPTAIN" Adaptors and Character Multiplex TVs. Furthermore, a built-in Tone Register with capacity for one tone allows for sound effects and original sounds creation. By controlling the parameters of this register (E, w1, I and w2 in the equation below), all kinds of harmonic can be created on the basis of the sample wave w1.

$$FM = E \sin (w_1t + I \sin w_2t)$$

Unlike conventional FM sound generators, this OPLL has a built-in Instruments ROM, permitting a substantial simplification of sound generation commands from the processor. First, the desired Instruments code is stored in the Instruments Selection Register. Then, after data has been input at the fixed intervals and timing, the unit starts generating sound. Processor automatic play can be easily performed by writing data appropriate to the music into the Sustain and Volume Registers. For using an original tone, the Instruments Selection Register must be cleared after writing data into the Tone Register as explained above. Rhythm sounds are generated by turning ON or OFF the corresponding bits in the Rhythm Control Register. In this case, the specified data must be input to the Key ON/OFF and F-Number Registers 8CH and 9CH.

REGISTER MAP

Address	D ₇	D ₆	D ₅	D ₄	D ₃	D ₂	D ₁	D ₀									
00	A	V	E	K	MULTI					User Tone Register							
01	M	B	TYP	S	R												
02	KSL		T L		⊗												
03			DC	DM	F B												
04	A R			D R													
05																	
06	S L			R R													
07																	
0E			R	BD	SD	TOM	T-CT	HH	Rhythm Control								
0F	T E S T								OPLL Test Data								
10	F-Num. 0 ~ 7								F-Number LSB 8 bits								
?																	
18																	
20			S	K	BLOCK			F	F-Number MSB, Octave set								
?			U	E	0 ~ 2			N	Key ON/OFF Register								
28			ON	ON				u	Sustain ON/OFF Register								
			OFF	OFF				m									
								9									
30	INST.			VOL					Instruments Selection and Volume Register								
?																	
38																	

YM2413**YAMAHA****Register Contents**

	Address	Bit	
1	00, 01	D7	Amplitude modulation ON/OFF switch
		D6	Vibrato ON/OFF switch
		D5	Sustained sound/decaying sound switch. 0: decaying sound 1: sustained sound
		D4	RATE key scale
		D0~D3	Controls MULTI sample wave - harmonics relationship
2	02, 03	D6 D7	LEVEL key scale
3	02	D0~D5	Modulated wave total level. Modulation index control
4	03	D3 D4	Carrier and modulated wave distortion waveform (flat wave rectification) ON/OFF switch
		D0~D2	FM feedback constant
5	04, 05	D4~D7	Attack envelope change rate control
		D0~D3	Decay envelope change rate control
6	06, 07	D4~D7	Indication of decay - sustain level
		D0~D3	Release envelope change rate control
7	0E	D5	Rhythm sound mode selection. 1: Rhythm sound mode 0: Melody sound mode
		D0~D4	Rhythm instruments ON/OFF switch
8	10~18	D0~D7	F-Number LSB 8 bits
9	20~28	D5	Sustain ON/OFF switch
		D4	Key ON/OFF
		D1~D3	Octave setting
		D0	F-Number MSB
10	30~38	D4~D7	Instruments selection
		D0~D3	Volume data

Tone Data

	Instrument		Instrument
0	Original	8	Organ
1	Violin	9	Horn
2	Guitar	10	Synthesizer
3	Piano	11	Harpsichord
4	Flute	12	Vibraphone
5	Clarinet	13	Synthesizer Bass
6	Oboe	14	Acoustic Bass
7	Trumpet	15	Electric Guitar

Envelope Waveforms

Decaying Sounds

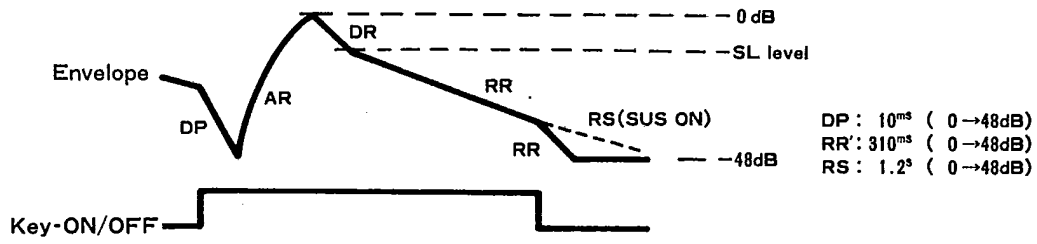

Sustained Sounds

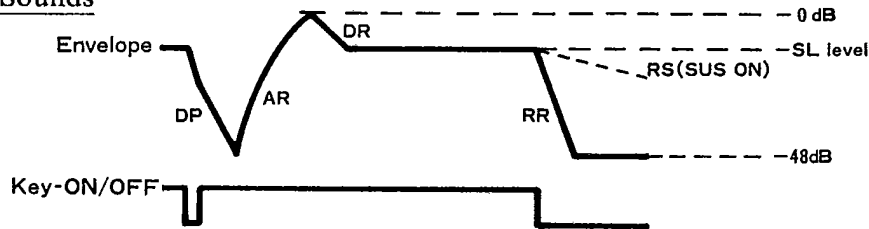

■ **TIMING DIAGRAMS** (Standard timing settings are $V_{IH} = 2.0V$, $V_{IL} = 0.8V$)

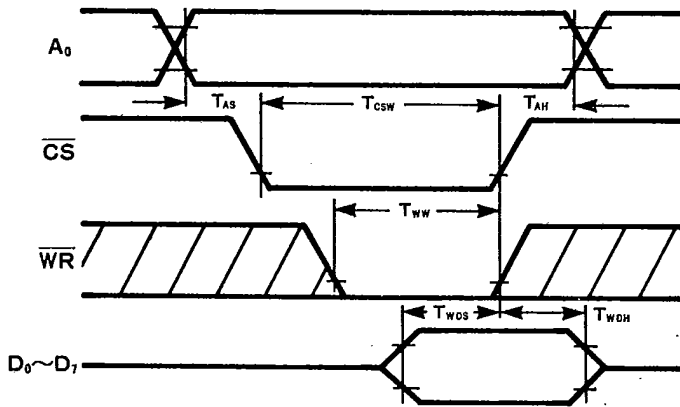

NOTE:
 T_{csW}, T_{ww} and T_{wDH} have been measured with either CS or WR high.

Fig. A-1 Write Timing

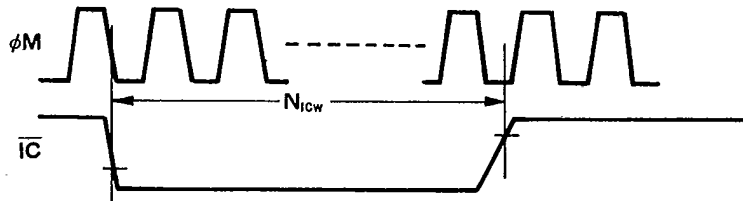

Fig. A-2 Reset Timing

YM2413**YAMAHA****■ ELECTRICAL CHARACTERISTICS****1. Absolute Maximum Ratings**

ITEM	RATING	UNIT
Pin voltage	0.3~7.0	V
Ambient operating temperature	0~70	°C
Storage temperature	-50~125	°C

2. Recommended Operating Conditions

ITEM	SYMBOL	MIN.	TYP.	MAX.	UNIT
Supply voltage	V _{CC}	4.75	5	5.25	V
	GND	0	0	0	V

3. DC Characteristics

ITEM		SYMBOL	CONDITION	MIN.	TYP.	MAX.	UNIT
High level input voltage	All input	V _{IH}		2.0			V
Low level input voltage	All input	V _{IL}				0.8	V
Leak input current	A0, \overline{WE}	I _L	V _{in} = 0~5 V	-10		10	μA
Three-state (off) input current	D ₀ ~D ₇	I _{TSL}	V _{in} = 0~5 V	-10		10	μA
Analog output voltage	MO	V _{MOA}	R _{LOAD} =				V _{pp}
	RO	V _{ROA}	R _{LOAD} =				V _{pp}
Pullup resistance	\overline{IC} , \overline{CS}	R _{PU}					KΩ
Input capacity	All input	C _I				10	PF
Output capacity	All input	C _O				10	PF
Power current		I _{CC}					mA

4. AC Characteristics

ITEM		SYMBOL	CONDITION	MIN.	TYP.	MAX.	UNIT
Address setup time	A ₀	T _{AS}	Fig. A-1				ns
Address hold time	A ₀	T _{AH}	Fig. A-1				ns
Chip select write width	\overline{CS}	T _{Csw}	Fig. A-1				ns
Write pulse write width	\overline{WE}	T _{ww}	Fig. A-1				ns
Write data setup time	D ₀ ~D ₇	T _{Ds}	Fig. A-1				ns
Write data hold time	D ₀ ~D ₇	T _{DH}	Fig. A-1				ns
Reset pulse width	\overline{IC}	N _{icw}	Fig. A-2				cycle

■ **OUTLINE DIMENSIONS**

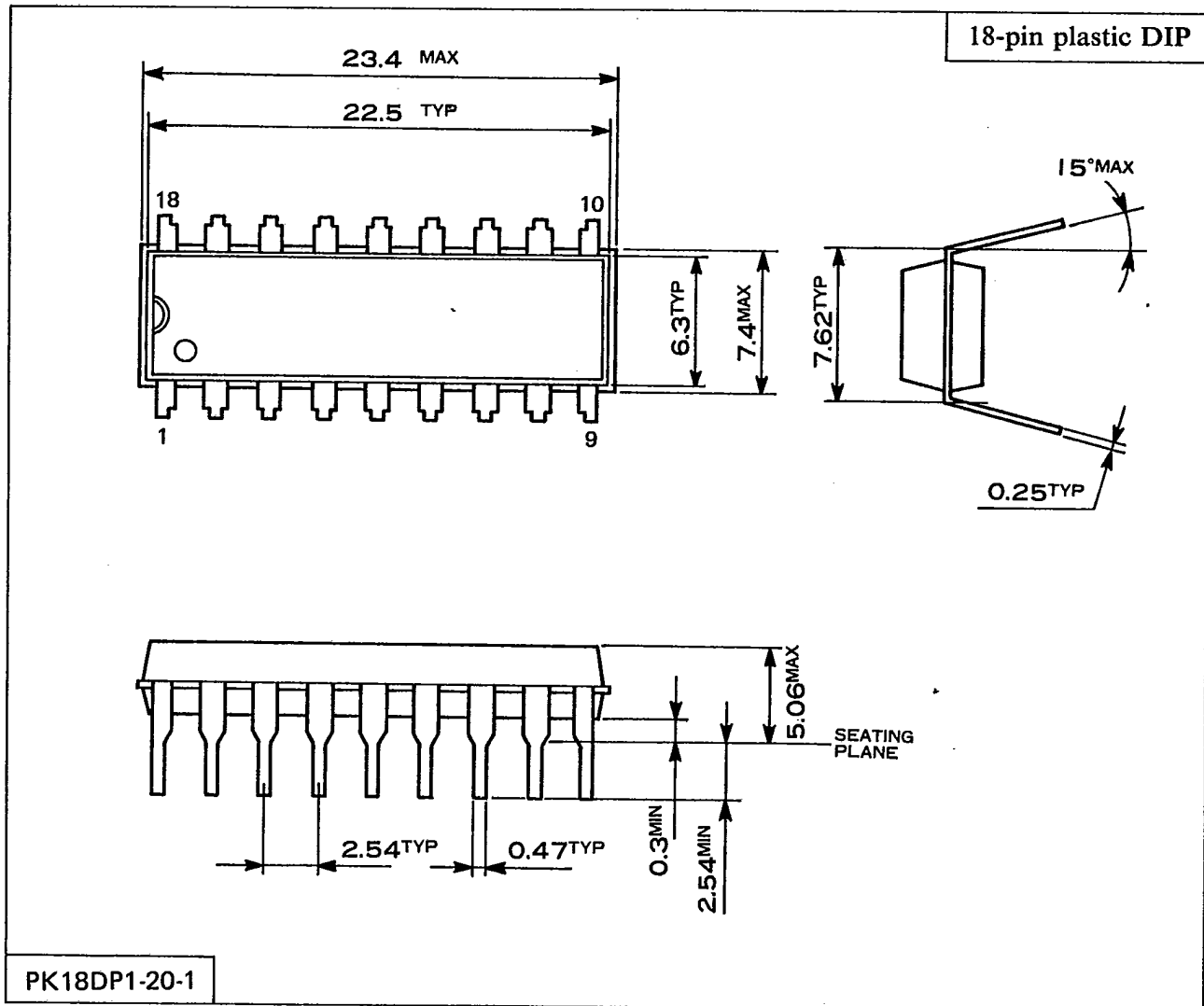

The specifications of this product are subject to improvement changes without prior notice.

_____ AGENCY _____

NIPPON GAKKI CO., LTD

■ **Head Office** 10-1, Nakazawa-cho, Hamamatsu-shi,
Shizuoka-ken, 430
Tel. 0534-65-1111

Address inquiries to:
Electronic System Division

■ **Toyooka Factory** 203, Matsunokijima, Toyooka-mura,
Iwata-gun, Shizuoka-ken, 438-01
Electronic Equipment business section
Tel. 053962-3125

■ **Tokyo Office** 3-4, Surugadai Kanda, Chiyoda-ku,
Tokyo, 104
Ryumeikan Bldg. 4F
Tel. 03-255-4481

■ **Osaka Office** 1-16, Shin-ashiyashimo, Suita-shi,
Osaka, 565
Tel. 06-877-7731